

# ORGANIZADORES

## Perchero Fijacion Superior



Código: 1101-130

Material: Acero  
Aluminio

Capacidad de Carga: 10 kg

Unidad de medida: Pieza

### Diagrama de ensamble

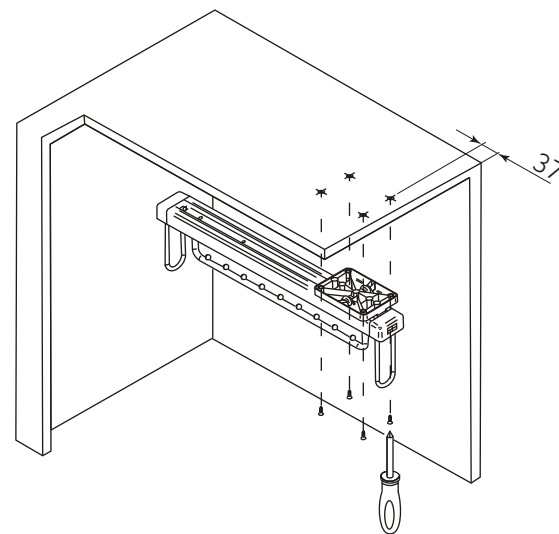
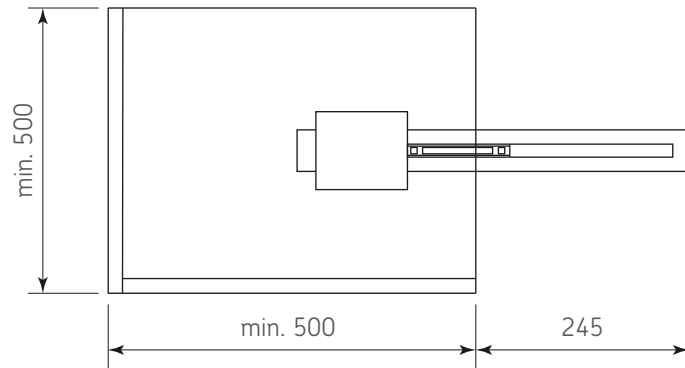

### Diagrama de producto

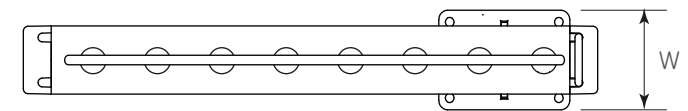
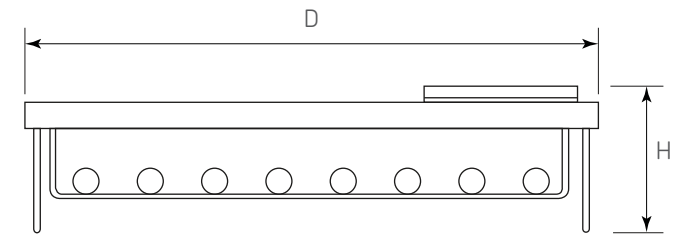

#### Dimensiones generales

W	D	H
85	460	165